

---

**Acorn Computers Limited  
Safety Test Guidelines  
recommended to meet the  
Electricity at Work  
Regulations 1989**

---

Copyright © Acorn Computers Limited 1993, 1994. All rights reserved.

Published by Acorn Computers Technical Publications Department.

No part of this publication may be reproduced or transmitted, in any form or by any means, electronic, mechanical, photocopying, recording or otherwise, or stored in any retrieval system of any nature, without the written permission of the copyright holder and the publisher, application for which shall be made to the publisher.

The products described in the manual are not intended for use as a critical component in life support devices or any system in which failure could be expected to result in personal injury.

The products described in this manual are subject to continuous development and improvement. All information of a technical nature and particulars of the products and their use (including the information and particulars in this manual) are given by Acorn Computers Limited in good faith. However, Acorn Computers Limited cannot accept any liability for any loss or damage arising from the use of any information or particulars in this manual, or any incorrect use of the products. All maintenance and service on the products must be carried out by Acorn Computers' authorised dealers or Approved Service Centres. Acorn Computers Limited can accept no liability whatsoever for any loss or damage caused by service, maintenance or repair by unauthorised personnel.

If you have any comments on this manual, please complete the form at the back of the manual and send it to the address given there.

ACORN, ARCHIMEDES and ECONET are trademarks of Acorn Computers Limited.  
All other trademarks are acknowledged.

Published by Acorn Computers Limited  
Part number 0472,204  
Issue 3, July 1994

# Part 1 — Test procedures

## Introduction

This Advice Note is intended to **assist** those responsible for setting up and maintaining the testing procedures necessary to implement the *Electricity at Work Regulations* 1989. These **general principles** should be used to write your own individual test procedure for Acorn equipment.

## Technical terms and abbreviations

The following terms and abbreviations are used in this Advice Note:

### Units of measurement

A	ampere
m	metre
Ohm	ohm
s	second
V	volt

### Unit prefixes

k	kilo- ( $10^3$ )
M	mega- ( $10^6$ )
m	milli- ( $10^{-3}$ )

### Abbreviations

AC	alternating current
PCB	printed circuit board
PSU	power supply unit
RFI	radio frequency interference
VAC	volts AC
VDC	volts DC
UUT	unit under test
EMC	electro-magnetic compatibility

## General advice and safety checks

Testing of any electrical equipment involves voltages and currents that, potentially, can cause injury to the operator, as well as damaging the UUT. It is the responsibility of both the employer and the operator to ensure that the operator is both trained and competent to test **each** piece of equipment.

The test equipment used should be a commercial appliance tester. These units are designed to simplify the test sequence as well as to protect the operator. The appliance tester used should have the following tests:

- 500VDC insulation test
- 8-25A earth test
- 100mV/100mA IT earth continuity test

It should also have some means of displaying the actual value of the test result rather than being a Pass /Fail display. This will allow you to monitor any progressive deterioration in the UUT from previously recorded results.

## Calibration

The test equipment should be maintained by a competent authority and periodically calibrated by a recognised calibration body. Failure to do so may cause a potentially dangerous UUT to appear safe.

## Safety

If you are unfamiliar with safety testing you should seek expert advice **before** you start testing. Some of the organisations listed in this document may be able to help you. There are also a number of firms that will carry out the requirements of the Regulations for your organisation. Some points to note are:

- Consult the test equipment instructions before and during testing.
- Test the equipment in the sequence set out in this document.
- Do not touch the equipment during testing.
- Ensure the equipment is not touching any conductive item during testing.
- If a test fails, stop testing, have the fault repaired and re-test from the beginning.

## Visual inspection

The equipment's mains cord and plug should be inspected for damage, and replaced if necessary, before any testing is started. If the cord is fixed to the equipment, replacement must be carried out by an authorised service centre. Opening any Acorn power supply will invalidate its warranty and could introduce a hazardous fault.

The cord should be routed so that it is not being either pulled or pinched. If it is an IEC "kettle" type then ensure that it is not being bent at the equipment because the equipment has been pushed back too far.

The equipment should have all its covers in place and be operated with enough space to allow free ventilation, especially near the fan openings.

## Mains cords

Some of Acorn's products are supplied with a removable IEC mains cord. You **must** test each such product with **its own cord**.

The resistance of the earth connection must be less than 0.1Ohm, but the resistance of the mains cord itself can be deducted from the overall resistance measurement. Consult the appliance tester manual for the resistance of the mains cord under test; normally 0.75mm<sup>2</sup> or 0.5mm<sup>2</sup>. For example:

$$2\text{m long mains cord @ } 0.75\text{mm}^2 = 0.06\text{Ohm}$$

$$2\text{m long mains cord @ } 0.5\text{mm}^2 = 0.08\text{Ohm}$$

## Fuses

The fuse in the mains plug, and any mains fuses accessible from **outside** the unit should be checked as being of the correct type and value. The plug fuse will be specified in the equipment's Welcome Guide, whilst the external fuse will be specified next to the fuse holder. Internal fuses should only be checked or replaced by an authorised Acorn service centre.

## Peripherals

Disconnect all external peripherals and external signal cables before starting any testing.

## Media

Remove any floppy discs or other removable media before testing.

## Software backups

Advise customers that their equipment is to be tested, and that they should make backup copies of any important software beforehand.

## Results

Record and keep the test results for future reference, so that you can spot any significant changes from previous tests. If the result is close to the pass mark, retest more frequently than normal (e.g. within six months).

### Remember:

If you are unsure how to test any equipment, seek advice **before** carrying out any tests.

## Earthing

Within the equipment there can be two types of earthing:

- Protective Earthing
- Functional Earthing.

### Protective Earthing

Protective Earthing (Class 1 equipment only) provides one level of protection from electric shock and as such must be safety tested. The basic electrical insulation of the PSU provides the required second level of protection.

### Functional Earthing

Functional Earthing (Class 1 and 2) reduces the effects of electrical noise and also provides a common reference point for interconnection signals. The PSU alone provides the two levels of protection necessary by having both basic insulation and supplementary insulation. If a functional earth is missing there will be no reduction in safety. You should not safety test functional earthing

connections – it is not required by the regulations, and applying high current to a functional earth point may well damage the equipment.

Within the Risc PC the EMC coating provides a functional earth to the Eurocard style expansion cards. The EMC gasket on the rear panel of the card contacts the coating at a number of points. These contact points are not capable of carrying the protective earth test current of 25 Amps. If a card is subjected to this high current the coating at the contact points will burn away and you will lose the functional / EMC earthing of the expansion card rear panel. This will not reduce the safety of the equipment but will compromise the EMC performance and possibly the functionality of the card.

## Class 1 Equipment

The equipment mains cord contains a protective earth /ground wire.

Suitable high-current test points are shown in *Appendix –Test points*.

In addition, test the earth connectors of any IEC outlet sockets.

Before testing expansion cards, seek advice from the manufacturer.

## Test 1: Earth continuity test

There are two methods that can be used for testing the earthing connections of an equipment: high current testing and low current testing.

### Warning:

High current testing can damage equipment containing integrated circuits. Be extremely careful as to how and where you test. Do not allow the test probe to touch any connector pins.

Decide which of the two test methods is appropriate.

### Method A: High current testing

The appliance tester should be capable of sourcing 8A (recommended) up to a maximum of 25A from an open circuit AC or DC voltage of less than 12V.

**Do not** connect the UUT to the mains

**Do not** test the signal pins of any connector

**Do not** test the outside shells of connectors (such as the video, TV and audio) which are connected to ground via thin PCB tracking (i.e. functional earthing).

**Do** test at known high current earth connection points.

To perform the test:

- 1 Apply the probe to the exposed clean metalwork of the UUT e.g. the PSU metal frame and its metal mounting screws. The other tester connection is to the mains plug earth pin of the UUT.

- 2 Keep the probe in **secure** contact with the UUT during application of the test current (movement may cause arcing which could damage the UUT).
- 3 Remove the test current after five to six seconds ( otherwise the heating effect of the current may damage the UUT).

The pass level is **less than** 0.1Ohm (after deducting the resistance of the mains cord).

**Method B: Low current testing**

This method should be used wherever you do not have positive information on test points.

**Do not** connect the UUT to the mains.  
**Do not** test the signal pins of any connector.

- To confirm that a point is connected to earth, use a meter
- with an open circuit voltage of less than 100mV
  - with a short circuit current of less than 100mA
  - capable of reliably measuring a resistance of 0.1 Ohm with an accuracy of 10%.

**Note:** Many appliance testers now incorporate the new HSE-approved test of 100mV at 100mA.

The pass level is **less than** 0.1Ohm (after deducting the resistance of the mains cord).

**Test 2: DC insulation test**

- 1 Turn the UUT's ON/OFF switch **ON**.
- 2 Connect the mains cord plug of the UUT into the appliance tester
- 3 Select the **DC insulation test** on the appliance tester  
 This shorts the Live and Neutral pins of the mains cord plug together, and should apply 500VDC between this connection and the earth pin)
- 4 Remove the applied voltage after five to six seconds. The pass level for a Class 1 unit is **greater than** 2MOhm. **Note:** If you are **not** using an appliance tester, use the adaptor shown below.

**Figure 1.1: Test adaptor**

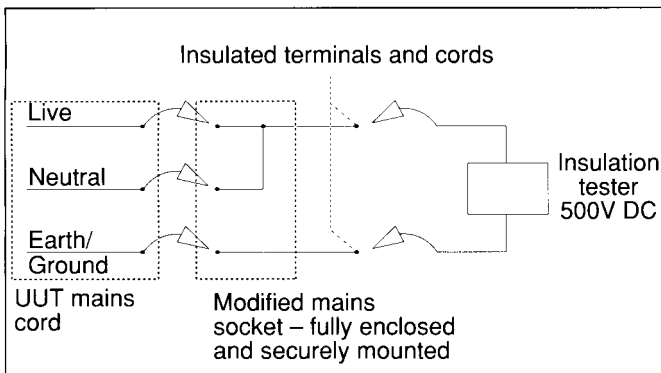

**Test 3: Flash test**

**Not recommended.** Called an *Electric Strength Test* in IEC950.

This normally means the application of an AC test voltage of 1.5kV to the UUT between the Live/Neutral node and the earth pin in order to highly stress the power supply insulation.

The majority of Acorn equipment is powered by switch mode power supplies. These incorporate RFI capacitors across the mains input in order to limit the amount of interference the equipment injects back into the building's mains circuit.

The application of this very large AC voltage to these devices is **not** recommended as they may well become over-stressed, especially if subjected to regular testing. In addition, the presence of these capacitors may well give erroneous readings on being tested, appearing to be a partial short circuit.

If, however, you still wish to apply a high-stress test to the power supply insulation of switch mode power supplies containing RFI capacitors, you should seek further advice from Acorn.

**Class 2 Equipment**

The mains cord has **no** protective Earth/Ground wire. This equipment relies solely on the two layers of insulation in the PSU, each of which provides sufficient protection so that if one fails the other will still protect the user against electric shock. Class 2 equipment should display the double-insulation symbol:



**DC insulation test**

See the Class 1 insulation test with the following additional comments.

- Consult the appliance tester's manual for the correct test procedure. The probe should not touch any connector during testing.
- The pass level for Class 2 equipment is **greater than** 7MOhm.

**Class 3 Equipment**

As defined in IEC380 and IEC950, this category of equipment contains no hazardous voltages (i.e. those that are greater than 42.4VAC or 60VDC, and therefore does **not** require testing.

An example is the **computer-only** section of the Master Compact system. This is supplied with a low, non-hazardous energising voltage by the external power supply mounted in the disc drive stand.

The disc drive stand, however, is itself powered from the mains supply via an earthed mains cord. This means that the stand, being Class 1, is the only part of the system that requires testing. The electrical safety of the system depends on the disc drive stand, its internal power supply unit and the mains cord earth connection to the stand.

**Note:** The thin two-core cable connecting the disc drive unit and the computer is **not** supplying a protective earth to the computer.

Disconnect the powered equipment (i.e. the computer) before testing the stand.

Some Acorn equipment, such as the Electron, is powered by an external transformer which is plugged directly into a mains socket. Here again the Electron does not require testing but the transformer does. The transformer will

normally be Class 2 and as such will be marked with the double-insulation symbol.

Disconnect the powered equipment (i.e. the computer) before testing the transformer.

**Note:** Some plug-in external transformers incorporate a metal "earth pin". In Class 2 equipment this is only used as a mechanical support, and is not actually an earth pin – look for the Class 2 symbol. (Conversely, Class 1 equipment **does** use this as an earth pin).

### Equipment design standards

The following equipment has been manufactured to the International safety standards as shown. This information is correct at time of going to press – contact Acorn Computers Limited for the most up-to-date information.

### Standards

- IEC 65 Safety requirements for mains-operated electronic and related apparatus for household and similar general use.
- IEC 380 Safety of electrically energised office machinery.
- IEC 950 Safety of information technology equipment including electrical business equipment (current standard).
- EN 60950 European 'harmonised' version of IEC 950; this single document is used by all EEC and EFTA countries.
- BS 7002 Identical English language version of EN 60950.

### Type tested

A single example is tested by an independent test organisation which produces a report which confirms compliance with the test standard.

The production site and build quality are not independently monitored.

Equipment:	Type Tested	Certified	Class	BS (IEC)	EN
Model A/B	No - D to C	No	1	415 (65)	n/a
Electron	No - D to C	No	2 and 3	415 (65)	n/a
Master Compact	Yes - BSI	No	1 and 3	5850 (380)	n/a
Master 128	No - D to C	No	1	415 (65)	n/a
Communicator	Yes - BABT	No	2 and 3	5850 (380)	n/a
A300/400	Yes - BSI	No	1	5850 (380)	n/a
A500 / R200	Yes - BSI	No	1	5850 (380)	n/a
A500 / R200	Yes - BSI	No	1	7002 (950)	60950
A3000 (UK)	Yes - BSI	No	1	5850 (380)	n/a
A3000 (Int.)	Yes - BSI	Yes	1	7002 (950)	60950
A3010/A3020	Yes - BSI	Yes	1	7002 (950)	60950
A4000	Yes - BSI	Yes	1	7002 (950)	60950
A4	Yes - BSI	No	1 and 3	7002 (950)	60950
Pocket Book	No - D to C	No	2 and 3	415 (65)	n/a
E01S	Yes - BSI	No	1	5850 (380)	n/a
E40S, E60S	No - D to C	No	1	5850 (380)	n/a
A5000	Yes - BSI	Yes	1	7002 (950)	60950
Risc PC	Yes - BSI	Yes	1	7002 (950)	60950

**Certified**

Same as type testing but, in addition, the site and build standard are regularly monitored by the test organisation (which allows the equipment to be marked with its registered symbol).

**EN**

European Norm which is the identifying prefix for EU 'harmonised' standards of which the BS document is merely the English language version.

**D to C**

The equipment has been designed to comply with the technical requirements of the standard, but may not have been independently tested.

**Organisations**

Edgcombe Instruments Ltd, Main St, Bothwell, Glasgow G71 8EZ. Telephone (0698) 852 574; FAX (0698) 854 442; TELEX 778873 EDGCUM G.

FEI (Federation of the Electronic Industries), Russell Square House, Russell Square, London WC1 B 5AE. Telephone (071) 331 2019; FAX (071) 331 2040.

The FEI produces an explanatory document on safety testing which covers the full range of business and office equipment. This is done with the full knowledge and co-operation of the HSE. The document is entitled *FEI Recommendations for periodic safety checks for business equipment*. Copies can be obtained from Christine Rolston at the Federation.

HSE (Health & Safety Executive) via HMSO Publications. For your local outlet, see the Telephone Directory.

Irwing-Desman Limited, 249 Purley Way, Croydon CR9 4QL. Telephone (081) 686 6441; FAX (081) 681 8429.

Megger Instruments Ltd, Archcliffe Road, Dover, Kent CT17 9EN. Telephone (0304) 202 620; FAX 0304 207 342; TELEX 96283 Avomeg G.

**Additional information sources**

Item	Source	Description
Portable Appliance Testing	Megger/Booklet	Information on testing.
Application Note No.1 Appliance Safety Testing	Megger/Leaflet	General advice
Portable Appliance Testing	Megger/Video	
Electrical Safety Testing	Seaward/Leaflet	General Advice
Memorandum of guidance on the Electricity at Work Reg. 1989	HSE /Booklet	Expansion on the Act
PM32: The safe use of portable Electrical Apparatus: Safety	HSE /Leaflet	General advice
HS(G)107: Maintaining portable and transportable electrical equipment	HSE /Booklet	General advice

Robin Electronics Ltd, Hirst Hall, GEC Centre, East Lane,  
Wembley, HA9 7YA. Telephone (081) 904 4383; FAX  
081 908 4101; TELEX 299891 ROBIN G.

Seaward Electronic Ltd, Bracken Hill, South West  
Industrial Estate, Peterlee, County Durham SR8 2JJ.  
Telephone (091) 586 3511; FAX (091) 586 0227; TELEX  
537 476 Seaward.



# Appendix A — Test points

## BBC Microcomputer test points

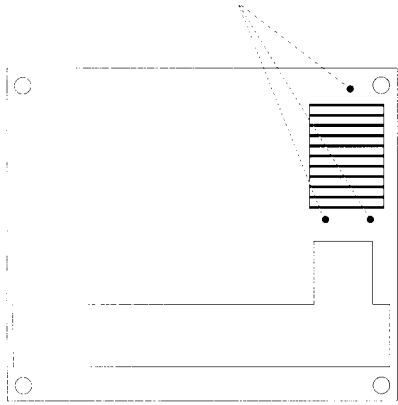

## Archimedes 400 series test points\*

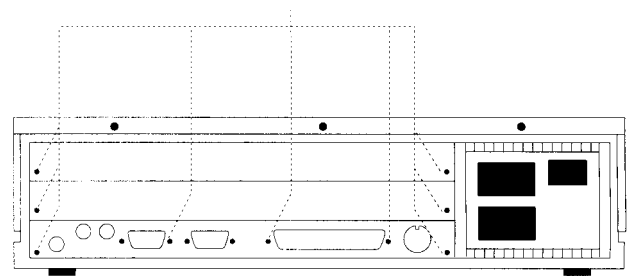

## A500/R200 series test points\*

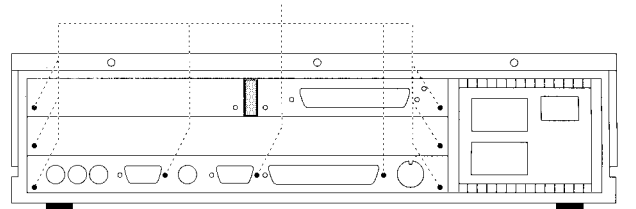

## Master test points

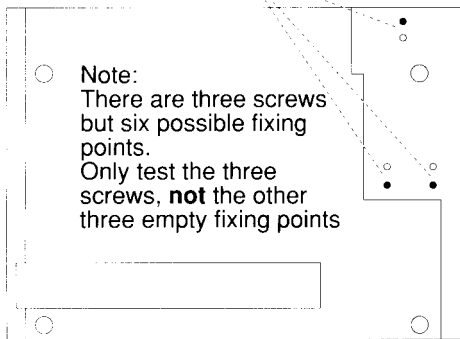

## A5000 test points\*

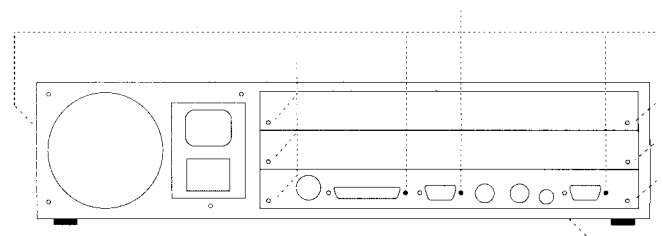

## A3000 test points

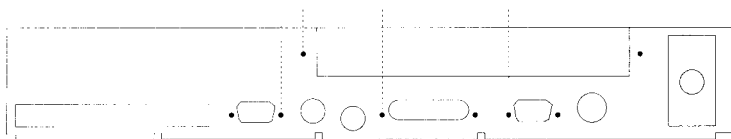

## A3010/A3020 test points

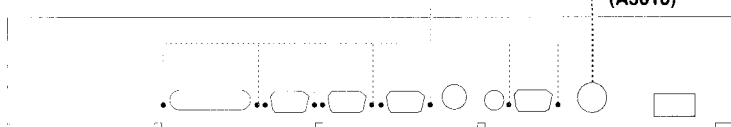

## A4000 test points\*

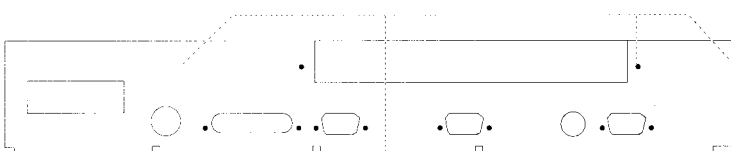

### \*Metal-cased equipment

Check continuity between power supply cord plug earth and the following points:

- Rear panel metalwork.
- Case — lower wrap. If it is necessary to remove paint from the lower wrap to ensure that a good connection is made, then this must be done somewhere so that it will not be visible to the end user (e.g. within cooling slots).
- Case — upper wrap (remove paint from cooling slots if necessary).
- Expansion card slot panel.

Risc PC test points

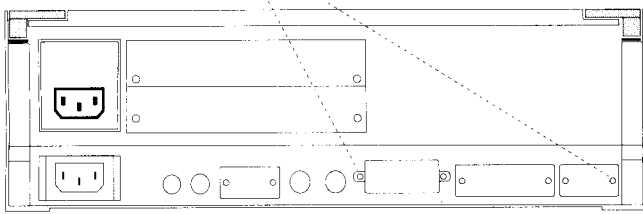

# Reader's Comment Form

## *Acorn Safety Test Guidelines (Issue 3)*

We would greatly appreciate your comments about this Manual, which will be taken into account for the next issue:

---

**Did you find the information you wanted?**

---

**Do you like the way the information is presented?**

||

ii

---

**General comments:**

||

||

If there is not enough room for your comments, please continue overleaf

*Cut out (or photocopy) and post to:*

Dept RC, Technical Publications  
Acorn Computers Limited  
Acorn House  
Vision Park, Histon  
Cambridge CB4 4AE  
England

**Your name and address :**

This information will only be used to get in touch with you in case we wish to explore your comments further

